

MX-###-##

 FUEL TYPE
 N= NATURAL GAS
 L=PROPANE

 OUTPUT VOLTAGE
 208=120/208 3 PH 60 Hz
 240=120/240 1 PH 60 Hz
 220=110/220 1 PH 50 Hz

 COLD AMBIENT OPTION
 CA= COLD AMBIENT OPTION INCLUDED
 BLANK= NO COLD AMBIENT OPTION INCLUDED

 OIL SYSTEM
 S= STANDBY
 L=EXTENDED RUN

303241-17 REV1



CONFIGURATIONS	
Fuel Type	Natural Gas Propane
Output Voltage	120/208V 3PH 60 Hz 120/240V 1PH 60 Hz 110/220V 1PH 50 Hz
Oil System	Standby Extended Run
Ambient Startup	Standard Cold Ambient

POWER SPECIFICATIONS								
Model	Maximum Output Rating @ 40°C						Max Unbalance W	Engine Speed RPM
	V	φ	HZ	Net Load kVA	Overload** kVA	COS φ		
MX-#-208-#-##	*120/208	3	60	6.0	8.0	0.8	500	1800
MX-#-240-#-##	*120/240	1	60	6.0	8.0	1.0	500	1800
MX-#-220-#-##	*110/220	1	50	6.0	7.1	1.0	500	1500

* Phase balancing is required when 120VAC or 110VAC loads are connected.
 **Overload condition occurs for 100 seconds or less at 40°C ambient. Lower load and cooler ambient conditions will increase the time of allowable overload conditions. Continuous overload will decrease engine life, reduce maintenance intervals, and may cause the electrical load to disconnect.

COMMUNICATION	
Ethernet	RJ45
Protocols	Modbus RS-485, Modbus TCP/IP
Inputs (Dry Contact)	Remote ON/OFF, Remote Start, External ESD, Alarm to PLC x4 (18-22 AWG)
Outputs (Dry Contact)	Alarm To SCADA, Out of Service, Load Status x3 (18-22 AWG)
Local Monitoring	4x20 OLED, Push Button Control
Remote Monitoring	IoT platform to monitor MX generators
Email Alerts	Alert users for important system information (requires IoT subscription)

OPERATING MODES	
Local	System on/off switch, generator start/stop buttons, ESD push button
Remote	Dry contacts – System on/off, generator start/stop, ESD, alarms
Manual	Generator starts and stops only through local or remote command
Auto-Standby	Generator starts and stops automatically when not in use to maintain battery voltage and engine temperature. Otherwise, unit runs normally while in use

ENVIRONMENTAL SPECIFICATIONS	
Sound	78 dB(A) or less @ 1 m 71 dB(A) or less @ 3 m
Ambient Rating (Continuous)*	-40°C (-40°F) to 40°C (104°F) Power derate required above 40°C (104°F)
Minimum Ambient (Startup)**	-5°C (23°F) without Cold Ambient configuration -40°C (-40°F) with Cold Ambient Configuration or running in Auto/Standby mode
Altitude	Ratings are tested at 1,047 m (3,435 ft) asl. Contact GPT for more information.
*Contact GPT for operation conditions below -40°C or above +40°C	
**For all configurations, Auto/Standby mode will keep the engine above 5°C so it can start at any time. Cold startup may require an external 120V AC power source to heat the engine block.	

FUEL SPECIFICATIONS							
		Natural Gas (MX-N-###-#-##)			Propane (MX-L-###-#-##)		
		-	Min	Max	-	Min	Max
Inlet pressure (Standard)	psig	-	2	5	-	2	5
	kPag	-	13.8	34.5	-	13.8	34.5
Inlet pressure w/ Regulator	psig	-	10	28	-	10	28
	kPag	-	68.9	193.1	-	68.9	193.1
Fuel BTU (LHV)*	BTU/scf	-	872	1066	-	2059	2523
	MJ/sm3	-	32.5	39.7	-	76.7	94.0
Fuel BTU (HHV)*	BTU/scf	-	966	1181	-	2226	2728
	MJ/sm3	-	36.0	44.0	-	82.94	101.64
Composition	%	[CH4]	80%	99%	[C3H8]	90%	100%
	%	[N2+CO2]	0%	10%	[C3H6]	0%	5%
	PPMv	[H2S]**	0	2 avg.	-	-	-
	PPMv	Total Sulphur	0	50	Total Sulphur	0	50
	Notes	Methane Number must be > 50. Gas shall not contain any liquids. Gas shall not contain any particulates. H2S must average 2 PPMv or less, and not exceed 4 PPMv at any time.			HD-5 Consumer Grade Propane or equivalent. Propane may need additional heating in cold temperatures to maintain vapor pressure.		
Fuel Consumption (HHV) and Flow Rates***	120/208V 3PH 60 Hz	kW	8.7	26.0	kW	8.4	24.1
		BTU/h	29,600	88,700	BTU/h	28,500	82,200
		SCFD	678	2,033	Gal/day	7.6	21.9
		Sm3/d	19.2	57.6	L/day	28.8	83.0
	120/240V 1PH 60 Hz	kW	9.1	26.9	kW	8.7	24.9
		BTU/h	31,000	91,700	BTU/h	29,800	85,000
		SCFD	710	2,103	Gal/day	7.9	22.7
		Sm3/d	20.1	59.6	L/day	30.1	85.8
	110/220V 1PH 50 Hz	kW	7.7	26.3	kW	7.4	24.3
		BTU/h	26,300	89,800	BTU/h	25,200	83,100
		SCFD	602	2,060	Gal/day	6.7	22.1
		Sm3/d	17.1	58.3	L/day	25.4	83.8

*Contact GPT for fuel BTU that are outside of the fuel specifications range

**If H2S is present in the gas stream, consult GPT before installation. An H2S removal system may be required. H2S must average 2 PPMv or less, and not exceed 4 PPMv at any time.

*** Flow rates calculated using Natural Gas HHV = 39.0 MJ/sm3, and Propane Gas 95.8 MJ/sm3. Propane gas consumption is converted to liquid consumption. Min fuel consumption is at 0 kVA net load, max consumption is at 6.0 kVA net load. Consumption will be higher than maximum if MX is overloaded.

ENGINE SPECIFICATIONS	
Prime Mover	Engine, Inline 3 cylinder, 4-Cycle Liquid Cooled, OHV Gear Drive
Fuels	Natural Gas or Propane (LPG)
RPM	1800 RPM or 1500 RPM
Max Shaft Output	NG: 11.7 kW LPG: 13.6 kW
Displacement	953 cc
Bore x Stroke	72 x 78 mm
Engine Oil	Mobil Pegasus 1 SAE 15W40
Engine Air Filters	Primary Radial and Safety Radial

ALTERNATOR SPECIFICATIONS	
Alternator	Brushless Synchronous with AVR 4 Poles
Insulation Class / Efficiency	H / 84.4%
THD	<3%
Protection	IP21
Rated Power, 3-PH at 60 Hz	12.0 kVA
Rated Power, 1-PH at 60 Hz	9.0 kVA
Rated Power, 1-PH at 50 Hz	7.5 kVA
Overload	110% for one hour in a 6 hour cycle

FUEL INTERFACE	
Customer Interface	1/2" Tube Union
Inlet Pressure* <i>Contact GPT for pressures outside of normal range</i>	2-5 PSI (Standard) 10-28 PSI (Regulator Option)
Regulator Option	Includes ball valve, regulator, pressure gauge

ELECTRICAL INTERFACE	
Customer Interface	4x 10 AWG 3-PH, 3X 10 AWG 1-PH
Customer Ground lug hole size	7/16" DIA [11mm]
Cable Gland size	3X-1 3/8" [35mm] hole for 1" Trade size conduit connection
Battery type	2X Sealed AGM deep cycle 12V DC 100-105 AH
Emergency Stop	Normally closed E-Stop

COOLING SYSTEM	
Cooling System	Fan Cooled Aluminum Radiator
Coolant Pump	Seal-less/Brushless 24V DC Centrifugal Pump
Coolant Fan	2X- 225x80mm, 24V, DC Axial fans
Coolant Type	Volvo Penta Yellow VCS Ethylene Glycol
Coolant Ratio	60/40 Ethylene Glycol/Water
Max Coolant Volume (mixed)	10 Liters (2.64 US gallons)

CONSTRUCTION	
Skid	CSA G40.21 44W Steel, 2-Coat Epoxy Paint, Semi-Gloss Black
Lifting Lugs	Included
Engine Enclosure	Steel, Powder Coated Grey, Polyurethane Foam Insulation UL-94 HF-1
Engine Access	Removable panels, tools required
Electrical Panel	Type 4, Steel, Powder Coated Grey
Electrical Panel Interface	ESD, On/Off, Start/Stop, Local/Remote, Manual/Auto, Status/Alarm LED
Electrical Panel Access	Door Access, tools required, LED display and breakers on inside
Enclosure Fans	2X- 225x80mm, 24V, DC Axial fans
Enclosure Filter	12x12x2" MERV 9 Pleated Filter

EMISSIONS

Fuel	CO ₂ e g/kW-hr	CO ₂ e @ 6 kVA tonnes/year
Natural Gas	820.7	52.9
Propane	992.5	64.0

For emissions measured in g/kW-hr, note that kW refers to the shaft power output of the engine. Emissions were measured and calculated on an 1800 RPM unit using a G2 test cycle using ISO 8178-G2 test modes and 40 CFR 1048.505 weighting. Results include deterioration factors calculated per 40 CFR 1054.245(c).

SERVICE INTERVALS

Model	Minimum service interval
MX-#-##-S-##	2,250 hours – Standby Oil System
MX-#-##-L-##	9,000 hours – Extended Run Oil system

CERTIFICATIONS

Safety	 Conforms to ANSI/CAN/UL/ULC STD 2200 Stationary Engine Generator Assemblies Control Number: 5024343
Emissions	Certificate of Conformity to EPA 40 CFR Part 1054 Small Nonroad Spark-Ignition Engines & Equipment Engine Family: NGPPS.9532MX (2022) Rated Speed: 1800 RPM Rated Fuels: Natural Gas and Propane

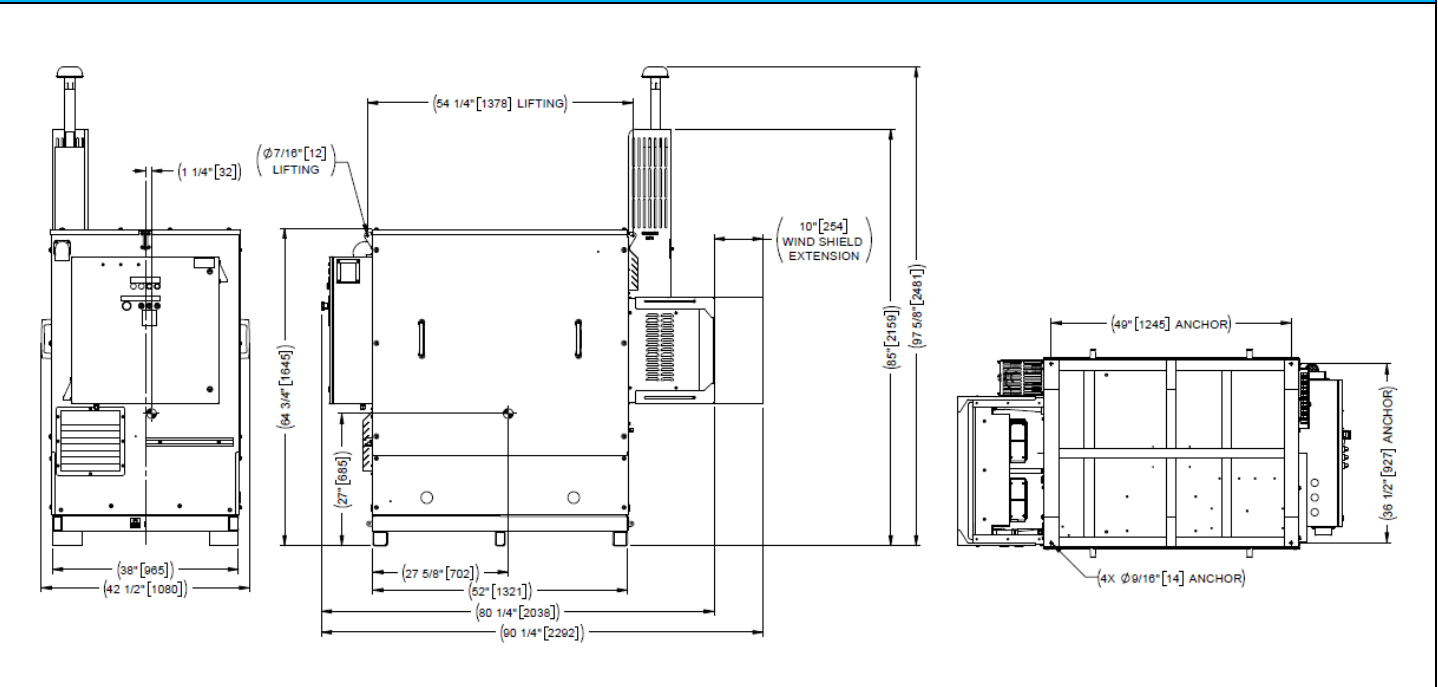
DIMENSIONS AND WEIGHT

Overall dimensions	90 1/4" x 42 1/2" x 97 5/8"
Weight (including fluids)	1750 lbs. [795kg]
Foundation Bolt pattern	49" x 36 1/2" x 9/16" DIA HOLE